



2141 ICON Way, Vacaville, CA 95688 - Tel: 707.564.4000 – www.iconaircraft.com

SERVICE BULLETIN

SB-041018 REV B

DATE ISSUED: 6/14/2018
DATE EFFECTIVE: 6/14/2018
SUPERSEDES NOTICE: SB-041018-A
SUBJECT: Rudder pedal brake master cylinder lower attachment bolt replacement and rod end inspection

AIRCRAFT AFFECTED: **MODEL:** ICON A5
S/N: 00001-00020, 00022-00036

REQUIRED ACTION: Inspect all brake master cylinder rod ends for corrosion and replace if necessary, replace brake master cylinder lower attachment bolts and carriage bolts with drilled head bolt for safety wiring.

TIME OF COMPLIANCE: At or before the next service intervention, or regularly scheduled maintenance event, but not to exceed the next one hundred (100) hours' time-in-service from the effective date above.

REVISION NOTES: Rev B: Updated distance between both rod ends (center of rod end to center of rod end) S/N Effectivity:
S/N: 00001-00020: 7.82 +/- .05 inches
S/N: 00022-00036: 6.94 +/- .05 inches

PURPOSE:

ICON is committed to designing, manufacturing, delivering, and supporting a high quality Light Sport Aircraft, providing a level of safety well beyond expectations. A recently received service report indicated that one of the brake master cylinder lower attachment bolts backed out and several other brake master cylinder lower bolts were found loose. This condition was only found on aircraft exposed to saltwater where the brake master cylinder rod ends were found corroded and seized. The purpose of this Service Bulletin is to provide instructions on replacing the brake master cylinder lower attachment bolts with drilled head bolts that can be safety wired along with replacement of any corroded brake master cylinder rod ends.

WARRANTY:

ICON Certified Service Providers: Please submit an invoice for warranty reimbursement for labor and parts on completion of this service bulletin. Please reference service bulletin number SB-041018.

1. 2-man hours of labor for disassembly, install of hardware, and reassembly.



2141 ICON Way, Vacaville, CA 95688 - Tel: 707.564.4000 – www.iconaircraft.com

SERVICE BULLETIN

SB-041018 REV B

PARTS LIST:

Part Number	Description	Quantity
ZM-001	Rod end, Beringer	A/N
AN3CH3A	Bolt, MACH, CRES, 10-32X.063	4
NAS6703HU8	Bolt, MACH, CRES, 10-32X.500	4
MOLYKOTE G4700	Lubricant	A/N
Loctite 243	Thread Locker	A/N
MS20995C32	Safety wire 0.032 in.	A/N

Instructions:

Special tools, fixtures, or test equipment:

1. Westward Needle nose grease fitting adapter Model number 13X058 or equivalent (shown in Figure 1)

PREPARATION:

1. It is permissible to disassemble the aircraft as required to permit accessibility, inspection, adjustment, maintenance, and repair in accordance with the latest release of the Aircraft Maintenance Manual, ICA000833.
2. Remove both forward and aft cockpit floors to gain access to the rudder pedal mechanisms.
3. Remove both the LH and RH instrument panel tops.
4. On Founders Edition aircraft (ASN00022 - beyond) it may make the job easier to remove the forward floor closeout panel by removing the attachment screw between the brake master cylinders. Then temporarily slide the panel forward to reveal the brake master cylinder bolts. However, the operation can be completed without doing this.

INSTALLATION:

1. Inspect all brake master cylinder rod ends for corrosion. If corrosion is present replace the rod end with new by following the below procedure. An example of unacceptable corrosion is shown in Figure 2.
2. If **NO** corrosion is present lubricate all brake master cylinder rod ends using a needle nose grease fitting adapter and Molykote G4700. Post lubrication, conduct lower attachment bolt replacement procedure below.

Brake Master Cylinder Rod end replacement

1. Remove both upper and lower brake master cylinder attachment bolts and retain hardware for re-installation
2. Remove corroded rod ends and discard
3. Replace corroded rod ends with new ZM-001 Rod ends. Lubricate the rod ends with Molykote



2141 ICON Way, Vacaville, CA 95688 - Tel: 707.564.4000 – www.iconaircraft.com

SERVICE BULLETIN

SB-041018 REV B

G4700 using the needle nose grease fitting adapter special tool.

4. Apply Loctite 243 to the new rod end threads prior to installation.
5. Set the distance between both rod ends (center of rod end to center of rod end) to 6.94 +/- 0.05 inches for S/N: 00022-00036 or 7.82 +/- 0.05 inches for S/N: 00001-00020.
6. Lock jam nuts and torque to 40-50 in-lb.
7. Reinstall brake pedal to brake master cylinder attachment bolt, washers, and bushings torque to 20 in-lb.
8. After complete, proceed to the brake master cylinder attachment bolt replacement procedure below:

Brake master cylinder lower attachment bolt replacement.

1. Remove the brake master cylinder lower bolts and discard, retain the washer and bushing.
2. Install new brake master cylinder lower attachment bolt with NAS6703HU8 bolt, torque to 26 in-lb as shown in figure 3 below.
3. Remove lower forward rudder pedal mechanism carriage bolt as shown in figure 3.
4. Install new lower forward rudder pedal mechanism carriage bolts with AN3CH3A, torque to 26 in-lb.
5. Safety wire the two bolts on each side together using 0.032" in safety wire as shown in Figure 4.
6. Repeat steps 1-5 of this procedure for both sets of rudder pedals.
7. Reassemble the aircraft.

SERVICE BULLETIN**SB-041018 REV B**

Figure 1: Needle nose grease fitting adapter.



Figure 2: Unacceptable Corrosion on rod end.

SERVICE BULLETIN

SB-041018 REV B

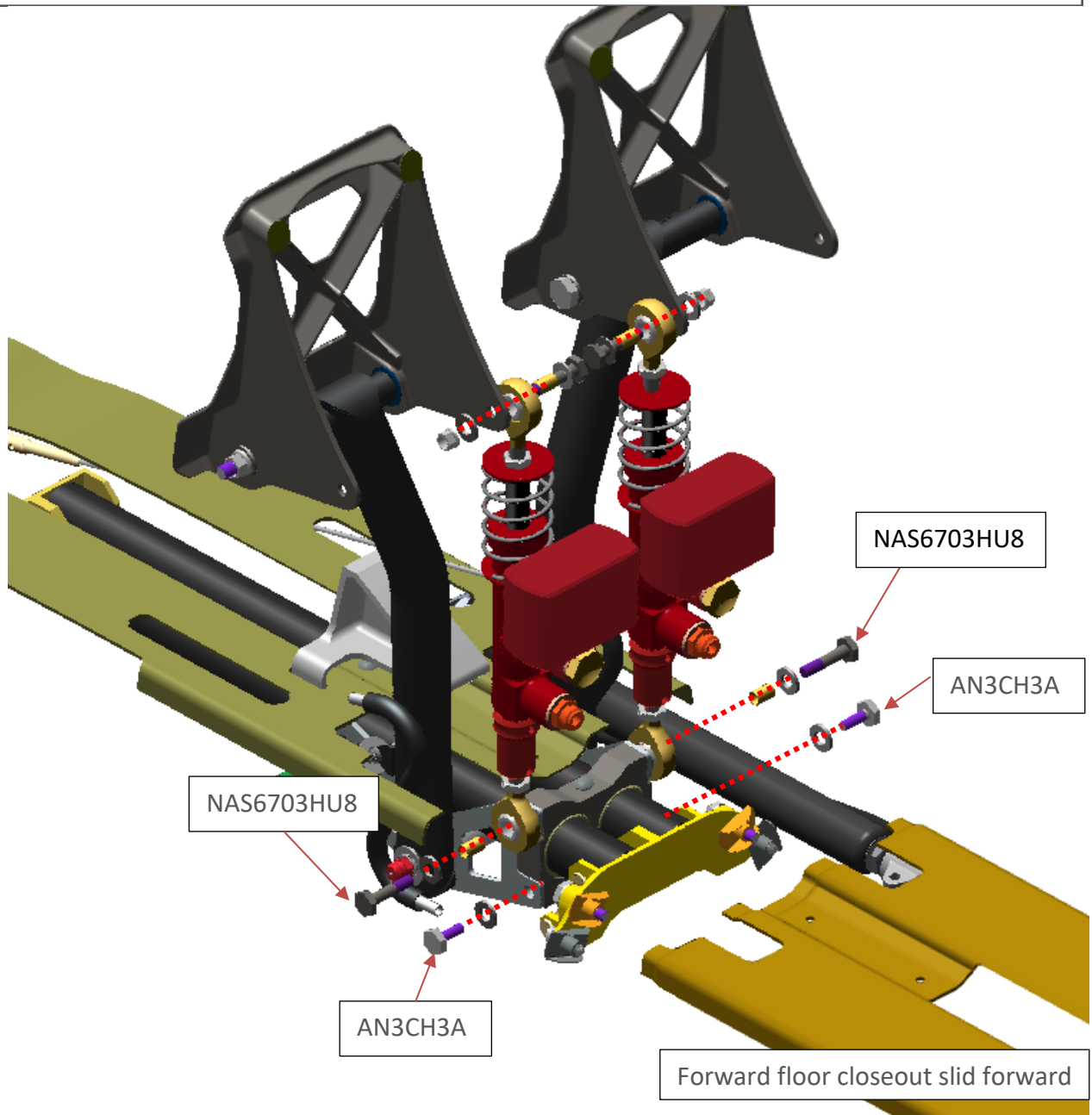

Figure 3: Brake master cylinder and rudder pedal carriage bolts to be replaced. Founder's Edition copilot rudder pedal design shown.

SERVICE BULLETIN

SB-041018 REV B

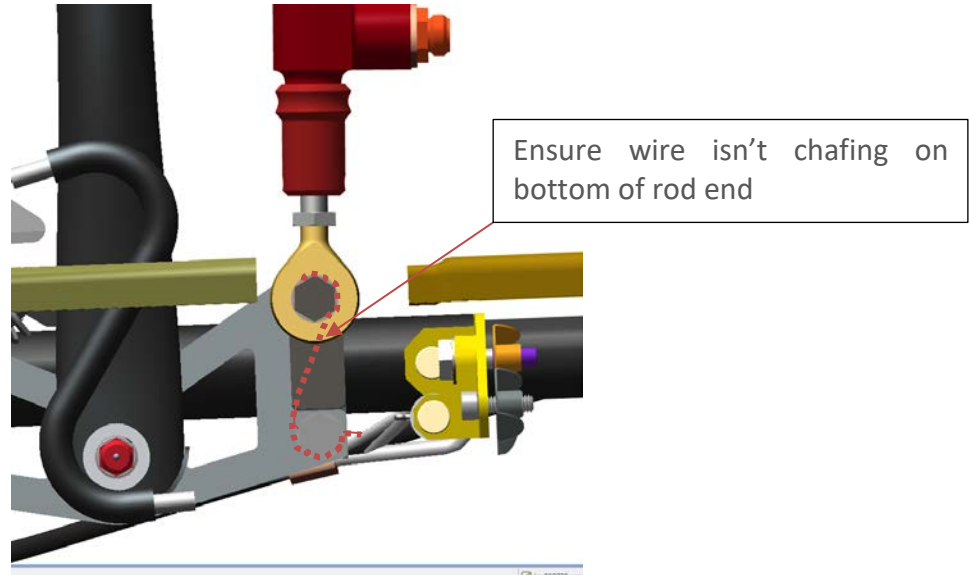

Figure 4: Safety wire detail.

VERIFICATION:

1. Move the rudder pedals throughout the range of motion and ensure there is no binding in the master cylinders.
2. Actuate the brakes and ensure the pedals return freely.

MAKE THE FOLLOWING LOGBOOK ENTRY:

“Service Bulletin (insert subject bulletin number) has been complied with and installation is reported to ICON Aircraft Customer Support and Service”.

If you need assistance relocating your A5 to your home base or temporary storage arrangements, please contact ICON Aircraft and ask for Customer Service and Support.

If you are no longer in possession of this aircraft, please forward this information to the present owner/operator and notify ICON Aircraft, Owners Center at:

ICON Aircraft
2141 ICON Way
Vacaville, CA 95688
(855) FLY-ICON or (707) 564-4000
support@iconaircraft.com

Please include the aircraft registration number, serial number, your name, and if known the contact information of the new owner/operator.



2141 ICON Way, Vacaville, CA 95688 - Tel: 707.564.4000 – www.iconaircraft.com

SERVICE BULLETIN

SB-041018 REV B

SERVICE BULLETIN APPROVAL

A handwritten signature in black ink, appearing to read "Bret Davenport".

Bret Davenport

Flight Sciences Manager

6/14/2018

NAME

TITLE

DATE

NAME

TITLE

DATE

NAME

TITLE

DATE

Confidentiality Note: The information contained in this document is confidential. Any dissemination, distribution, or copy of this document, in whole or in part, is strictly prohibited without prior written authorization by ICON Aircraft Inc.